

PART NAME

PLASTIBOX (STYLE F)

PART No.

PS-11533

MATERIAL: HIGH-IMPACT ABS
COLOR: BLACK OR GRAY
FINISH: TEXTURED BODY WITH
SMOOTH TOP INSERT

FOUR (4) #4 x 3/8 LG. SCREWS
SUPPLIED FOR ASSEMBLING TOP.

FOUR (4) NON-SKID PUSH-ON FEET SUPPLIED

*-USABLE AREA ON TOP ALSO
AVAILABLE FOR CUSTOM MOLDING.

NOTE: ALL DIMENSIONS HAVE ±0.015 TOLERANCE
UNLESS OTHERWISE SPECIFIED.

MOUNTING BOSSES USE EITHER M2.5 METRIC
OR #4 STD. SHEET METAL SCREWS
x 3/16 LG. (NOT SUPPLIED)

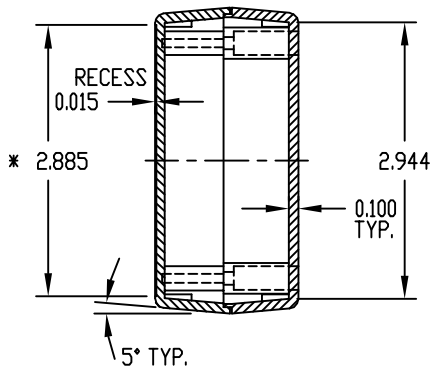
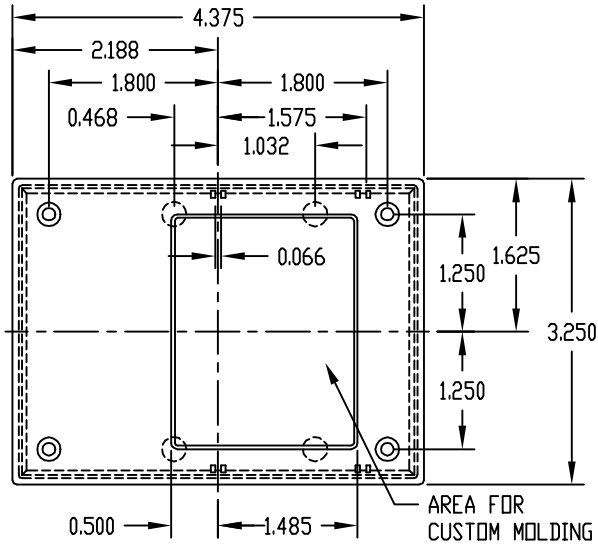
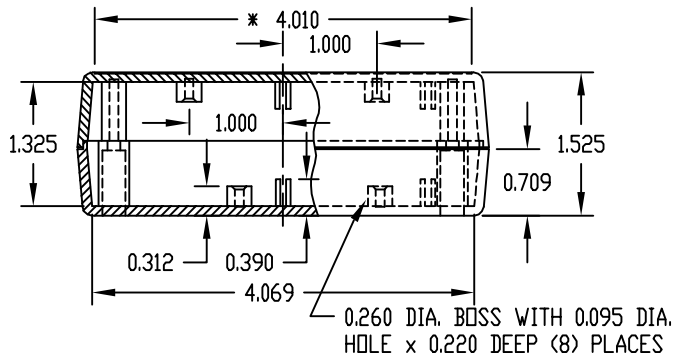

PART NAME

PLASTIBOX (STYLE F)

PART No.

PS-11543

MATERIAL: HIGH-IMPACT ABS
COLOR: BLACK OR GRAY
FINISH: TEXTURED BODY WITH
SMOOTH TOP INSERT

FOUR (4) #4 x 3/8 LG. SCREWS
SUPPLIED FOR ASSEMBLING TOP.

FOUR (4) NON-SKID PUSH-ON FEET SUPPLIED

*-USABLE AREA ON TOP ALSO
AVAILABLE FOR CUSTOM MOLDING.

NOTE: ALL DIMENSIONS HAVE ±0.015 TOLERANCE
UNLESS OTHERWISE SPECIFIED.

MOUNTING BOSSES USE EITHER M2.5 METRIC
OR #4 STD. SHEET METAL SCREWS
x 3/16 LG. (NOT SUPPLIED)

